



Premier-Roll Micro-Roll Eco-Roll

Installation Manual
for Remote Control
Rolling Garage Door



From Design to Installation
Only One Name is Recommended



Premier-Roll

Specially Designed For Low
Headroom Application



Micro-Roll

Why Compromise On Quality
When Working To A Budget



Eco-Roll

*Fully Remote Control
Insulated Rolling
Garage Door*

Pre-Installation Checks

Ensure that the site is clear and that all fixing surfaces are free from loose plaster or masonry. Ensure the opening has no irregularities that could damage or mark the optional back box or curtain.

Unpacking The Door

The door curtain will be fully packaged when delivered, if the optional back and front box have been ordered. The head plates will be factory fitted to the back box and will have the curtain packed and rolled inside. The side guides are designed with spacing legs inside the box to ensure that the guide is a good fit to the head plate. Ensure that the guides are the correct way round. (See Fig. 1)

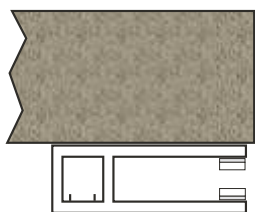
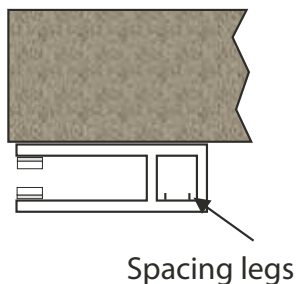
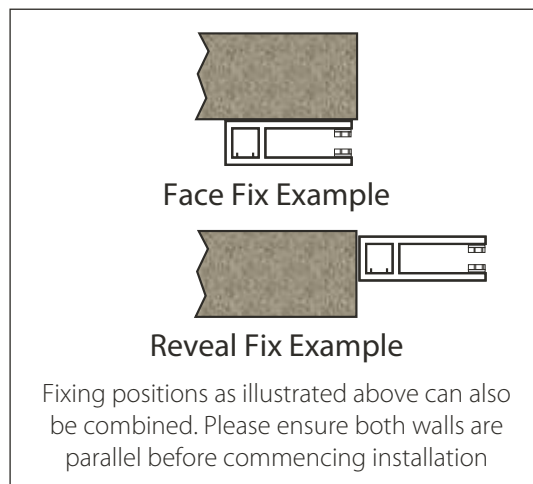

Fig 1



Note: Spacing legs ensure head plate is a flush fit against the opening.



Step 1 | Setting Out Your Installation

If your door is fitted with a back box, please move to step 2 as your overall size is pre-set.

If your door does not have the optional back or front box, please use the following layout instructions:

To determine back of plate size, you must measure the cut size of the door curtain; cut size does not include the plastic end locks. Once you have determined the cut size dimension, please add 105mm to give you the overall manufactured door width. Measure the garage door opening and deduct this from the overall width, whatever size is remaining is divided in two and marked on the garage wall. This is your overall door position.

Step 2 | Preparing the Guide Rails

- (A) Drill fixing holes (7mm) through the side channel box section starting 150mm from the bottom and evenly space thereafter, your last hole should be 150mm from the top of the guide. Enlarge your fixing hole to (10mm) on the Inside face of the guide section to accept the cover grommets.

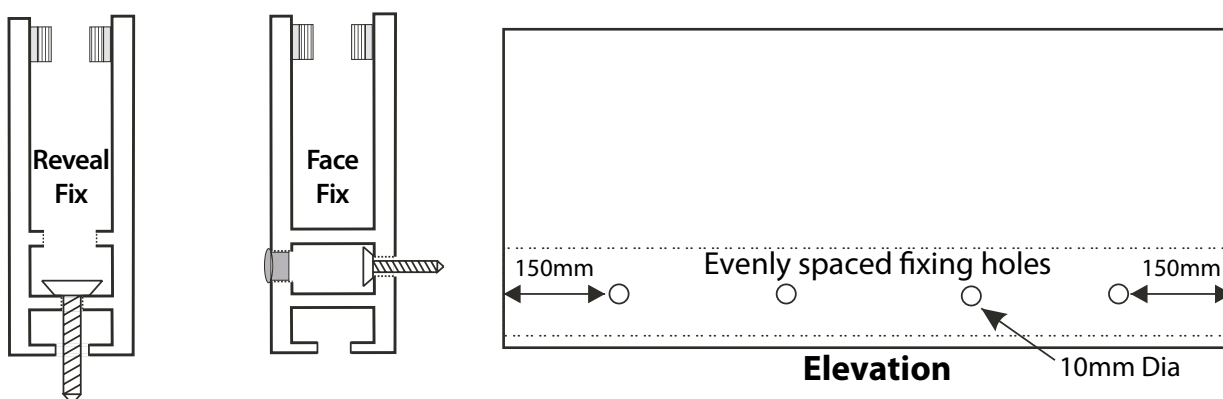

Step 3 | Preparing The Head Plates

Drill a 7mm fixing hole in the top corner of each plate.

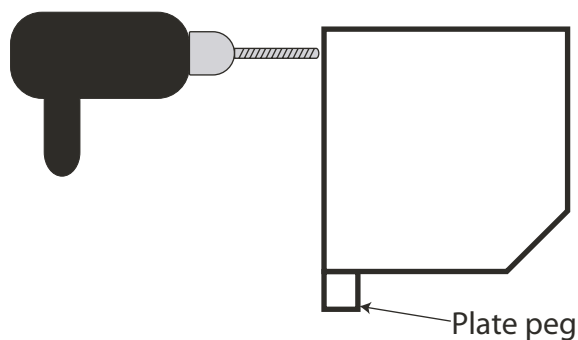

Step 4 | Assembling & Fixing The Door Guides & Plates

Fit the plate peg into the top of the guide section box, stand the guides upright. Level the guides with the garage opening. Check vertical level on both guide sections as well as horizontal level across the plates.

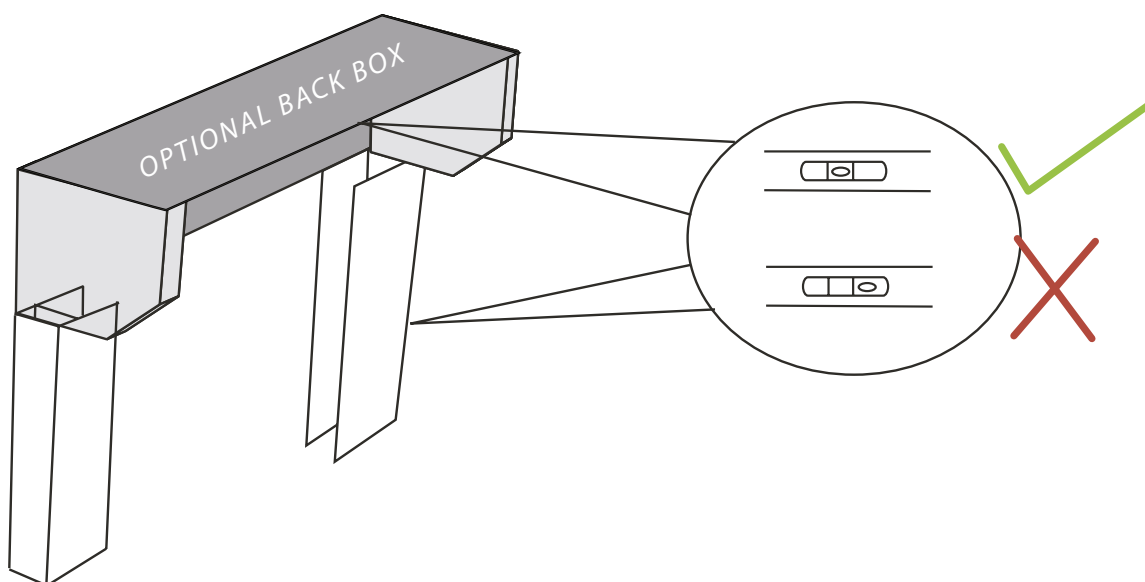

NOTE: If the optional back box has been ordered, you can install the barrel into the head plates before lifting into position. (See Step7)

Step 5 | Fixing The Guide Sections

Fix the guides into place using the fixing holes previously drilled, in Step 2. Secure each guide using a central fixing hole. Ensure that the guides are level, then completely fix the guide sections. Do not over tighten the fixings to compensate for mounting surface distortions, please pack walls, if required.

PLEASE ENSURE FIXINGS USED ARE SUITABLE FOR THE GARAGE WALL BUILD PROPERTIES

Step 6 | Fixing The Head Plates

Fix the head-plates into position ensuring that the head-plates are level and that the locating pegs are fully located into the guide section. Where a back box is fitted it may be necessary to fix the back box to the opening header to stop any marking of the curtain during door operation. If additional fixings are required in the back box, use countersunk screws, ensuring that the screw heads do not protrude, as curtain damage could occur.

Step 7 | Motor Barrel Assembly

The motor barrel is held in place by a captive bearing on the non-drive end of the motor barrel, and a motor backing plate on the motor end of the barrel. The motor mounting plate will be pre-fitted to the motor, and the bearing will be already captive on the non drive end plate. The non drive end of the barrel has an adjustable shaft which is held in place by a tensile Allen bolt, this must be released during installation of the barrel.

NOTE: If the optional back box has been ordered, you can install the barrel into the head plates before lifting into position.

- (1) Using 6mm Allen key, loosen the non-drive end Allen bolt, allowing the shaft to move in and out of the barrel tube freely.

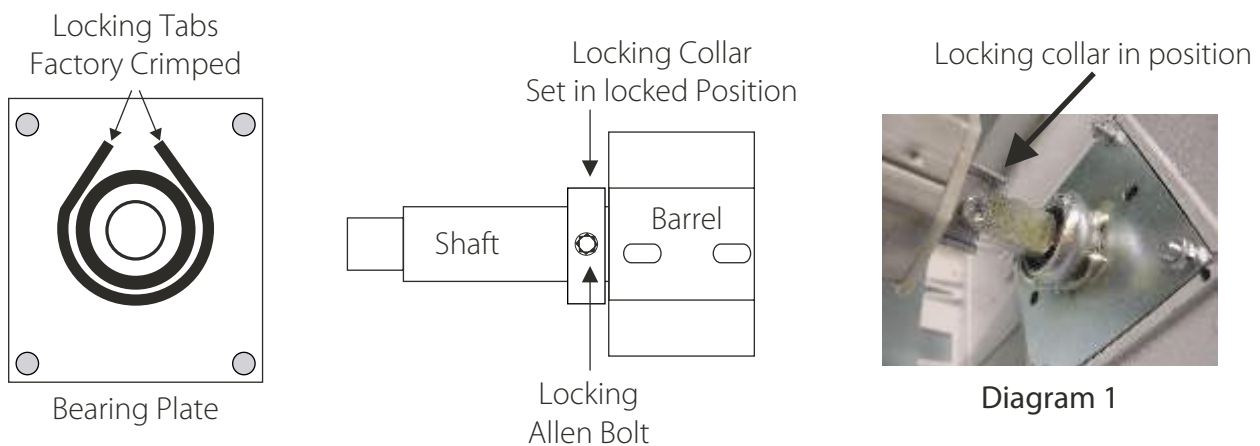

- (2) Using the four countersunk bolts and nuts supplied, fit the barrel into position, making sure the over-ride position is at the required point.

Please check over-ride outlet position with the diagrams on the next page.

- (3) When the motor over-ride has been decided, tighten the motor into position in the head plate using a 10mm socket.
- (4) Fully extend the non-drive end shaft until the bearing is sitting in the bearing housing.
- (5) Lock off the non-drive end shaft using a 6mm Allen key, ensuring that the lock plate is tight against the motor barrel (See Diagram 1).

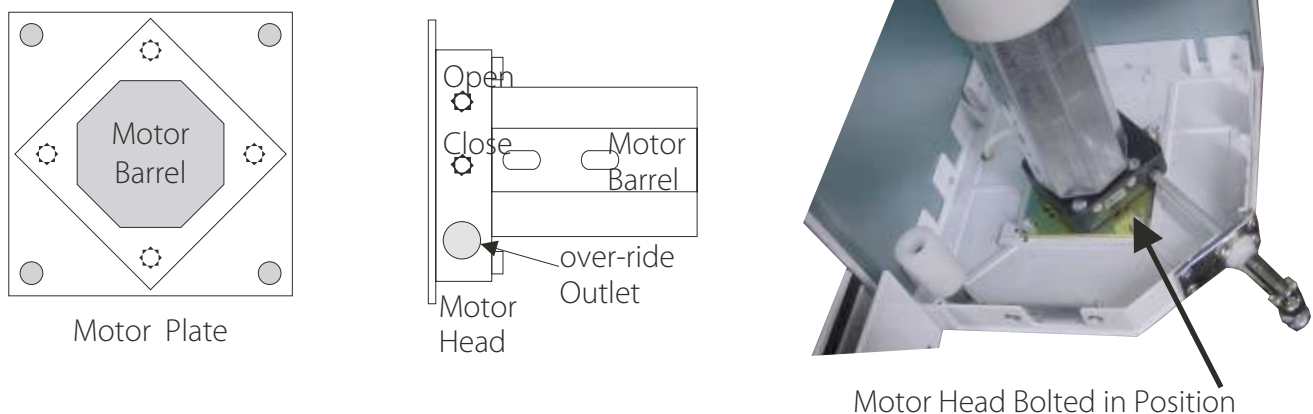

Step 8 | Installing The Manual Over-Ride

The manual over-ride eyelet and bar comes complete with a universal joint fitted to enable the emergency winding eye to always be accessible. The head plates are already prepared with pre-pressed exit points for the over-ride facility, depending upon your desired exit point.

Internal over-ride (Fig 1)

The head plate has a pre-pressed indentation on the 45 degree bevel edge internal face.

- (A) Cut down the pre-pressed line with a junior hacksaw & remove tab using pliers or similar tools.
- (B) Cut Universal over-ride bar to length. Insert over-ride bar through motor unit and fasten to head plate using self tapping screws.

Note: If your door has an optional internal cover do not insert over-ride bar until internal cover has been installed. (See step 14)

Internal Over-Ride (fig 1)

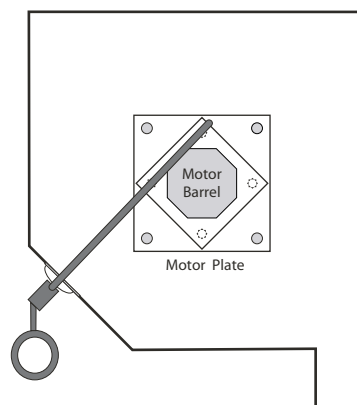

External Over-Ride (fig. 2)

The head plate has a pre-cut section on the outside face of the head plate, which will allow the over-ride bar to pass through.

- (A) Cut Universal over-ride bar to length.
- (B) Insert over-ride bar through motor unit and fasten to head plate using self tapping screws.

External Over-Ride (fig 2)

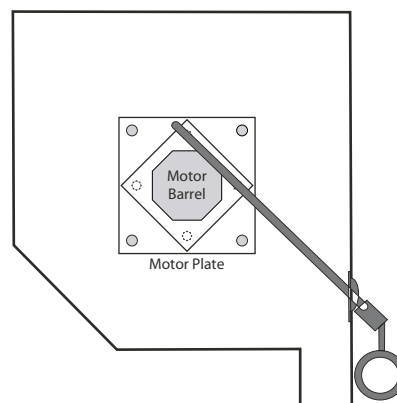

External Over-Ride (fig. 3)

The head plate has a pre-cut section on the outside face of the head plate, which will allow the over-ride bar to pass through. If an optional back box is installed and/or the door installation is a face fix the garage wall will also need to be drilled.

- (A) Cut Universal over-ride bar to length.
- (B) Insert over-ride bar through motor unit and fasten to external wall using screws & plastic plugs.

Note: When installing over-ride facility to the external elevation of the garage please ensure that the **SECURITY CLOSE** is activated on the remote receiver unit. (See Step 10)

External Over-Ride (fig 3)

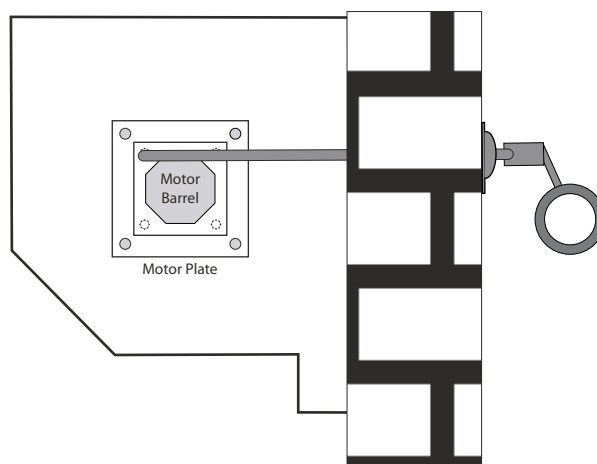

Step 9 | Mounting & Connecting The Controls

The Remote Control Unit should be mounted as close to the door as possible, approximately at shoulder height. This is to allow easy access to the receiver mounted control button. The remote control unit packaging incorporates a fixing hole stencil on the packaging front cover for ease of installation. Please use fixing kit as supplied with remote control unit. Masonry drill size required: 6mm.

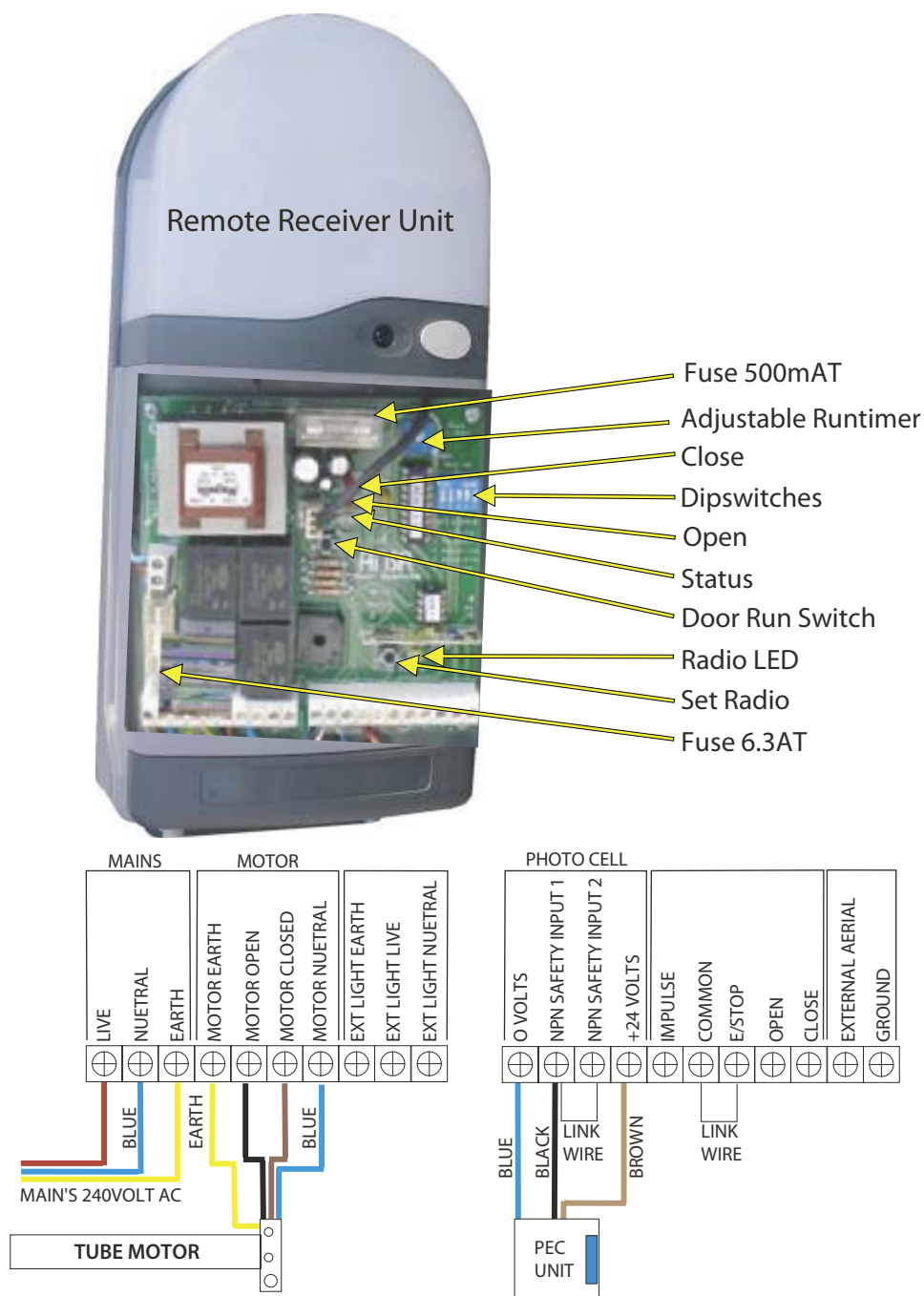

ENSURE MOTOR DIRECTION MATCHES INDICATION LIGHTS ON RECEIVER, TO REVERSE MOTOR DIRECTION SWAP MOTOR OPEN & MOTOR CLOSE CONNECTIONS.

SETTING LIMIT SWITCHES

The Remote Receiver is factory set for screw type limits with dip-switch 3 to the ON position as **FIG1** and the run time setting set to maximum. For push type limits turn dip-switch 3 to OFF as **FIG2**. Once the limits are set please return the dip-switches to normal running as **FIG2**.

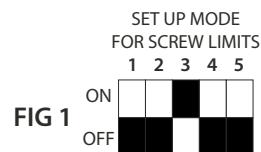

Step 10 | Adding & Deleting Transmitters

Adding Transmitters

- (1) Press & hold the receiver mounted operating switch for 5 seconds & release the receiver. Mounted LED will go out & flash once.
- (2) Take the hand transmitter to be added and press the button once the receiver mounted LED flashes once.
- (3) Press the Receiver mounted LED once or wait thirty seconds, the new transmitter is added.

Deleting Transmitters

- (1) Isolate the mains power to the receiver unit and remove the front cover.
- (2) Move dip-switch 5 to ON and re-power the unit.
- (3) Turn the mains power to the receiver unit back on.
- (4) The board mounted LED (green) will flash for five seconds, the hand transmitters are now deleted.

Note: The above procedure deletes *all* transmitters from the receiver. Existing transmitters must be reloaded using **adding transmitters** procedure.

Step 10a | Remote Receiver Unit

The remote receiver unit has five onboard dip-switches which control the following features:

Dip-switch 1 - WARNING

When switched to on will flash the on-built light unit three times before each operation.

Dip-switch 2 - RETRACT

Instead of the door returning to fully open when the photo-cell activated the door retracts 200mm only.

Dip-switch 3 - SECURITY

When using an external manual over-ride the door will power close every time the manual over-ride is used.

Dip-switch 4 - AUTO-CLOSE

Note: Additional safety edge system is recommended with Auto-close facility. The door will automatically close if left in the open position. Time lapse is adjustable via the run time fine adjuster (factory set to Maximum)

Dip-switch 5 - DECODE

Used when removing lost or stolen transmitters from the receiver memory. (See deleting transmitters).

AUXILIARY LIGHT RELAY

The on-built courtesy light unit is pre-wired, and an additional light unit can be used in conjunction with the remote receiver. Using Connections marked external light, a Light unit of up to 500 watts can be powered.

ADDITIONAL SWITCHES

Additional switches can be wired into the receiver unit using connections marked as Optional Switches. To wire a remote bell push use connections IMPULSE & COMMON leaving the link wire in position see diagram below.

OPTIONAL EXTERNAL AERIAL

The Remote receiver has an inbuilt Aerial which will enable good reception in most situations. If an external Aerial is required, please use terminals marked External Aerial.

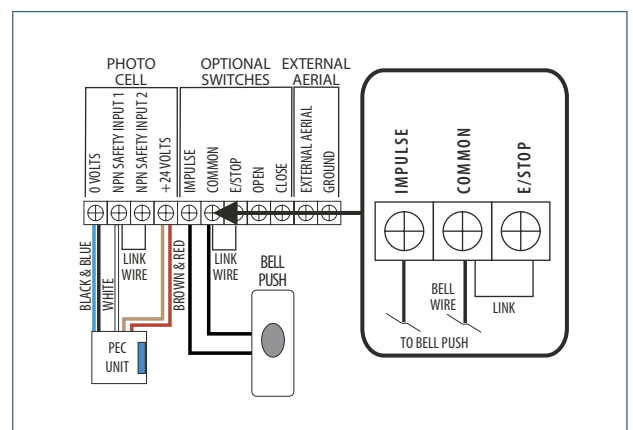

Step 11 | Mounting & Adjusting The Photo Electric Cell (PEC)

The Photo Electric Cell or PEC comes with a wall mounting bracket to carry the photo cell unit. The PEC can also be mounted directly to the side guide using self tapping screws.

Note: The correct installation height for the PEC is approximately 300mm from floor level.

- (A) Once the PEC is mounted to the door and the power to the Remote Control is switched on the, LED on the remote control receiver will start to flash rapidly. The Indicator lights on the PEC are amber and green, the green light indicates power to the PEC with the amber light illuminating when the unit is activated. (See Fig 1)
- (B) To mount the reflector, simply hold the reflector in place on the opposite side guide to the PEC and move the reflector slowly until the Receiver mounted LED stops flashing, the amber beam activation light on the PEC unit will also extinguish, this indicates PEC alignment is correct. Fix the reflector in the aligned position.

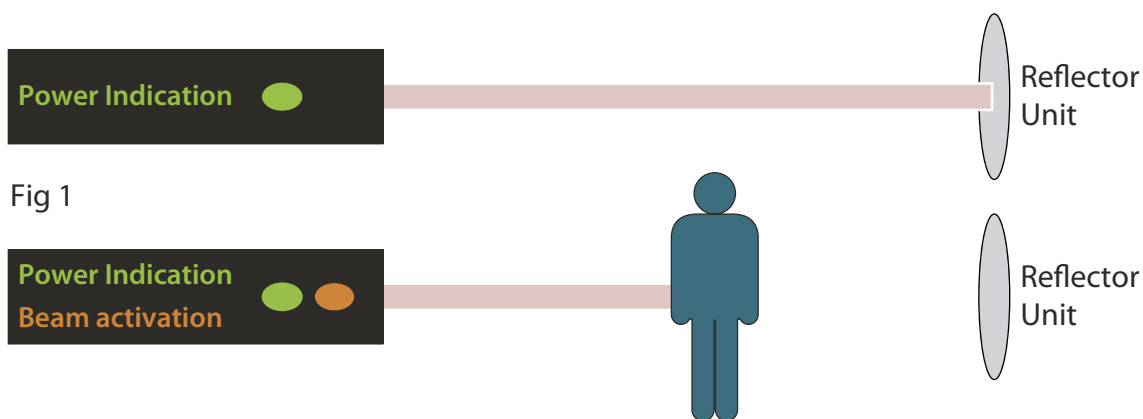

PEC mounted on the guide section



Reflector Unit (Wall Mounted)

Step 12 | Installing The Door Curtains

Before we can install the door curtain the motor barrel limit for the close position must be set. This is a simple operation.

- (1) Power the Receiver unit up, take a keyfob transmitter and press the button. The barrel will rotate in the close direction approximately two rotations and stop.

Note: If the barrel rotation is incorrect please swap motor direction connections

- (2) The Door curtain is delivered ready rolled for installation with the bottom section to the outside of the roll. To ensure the curtain does not get scratched during installation, the motor barrel metal tube should be covered by cardboard or bubble wrap..
- (3) Lift the rolled curtain and feed the bottom rail over the barrel section into the guides.
- (4) Feed the door into the guides approximately half way. Un-roll the remaining curtain, so the curtain is hanging over the motor barrel. (See Fig 1, following page)



Fig 1



Fig 2

Slide onto the top lathe of the door curtain the curtain connection clips or Auto-locking units (optional). Slide onto the top lathe of the door curtain, the curtain connection clips provided (Fig 2). Carefully slide the door curtain down to the closed position.

Step 13 | Auto-Locks (Optional)

Slip the Auto-lock rings onto the location pegs, ensuring that all Pegs are in the same hole series. Secure In place with the self tapping screws provided. (See Fig 4)

Note: The self tapping screws do not fix through the barrel wall. (See Fig 3)

Fig 3

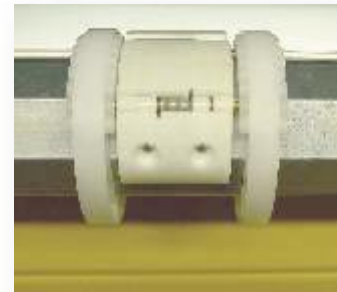
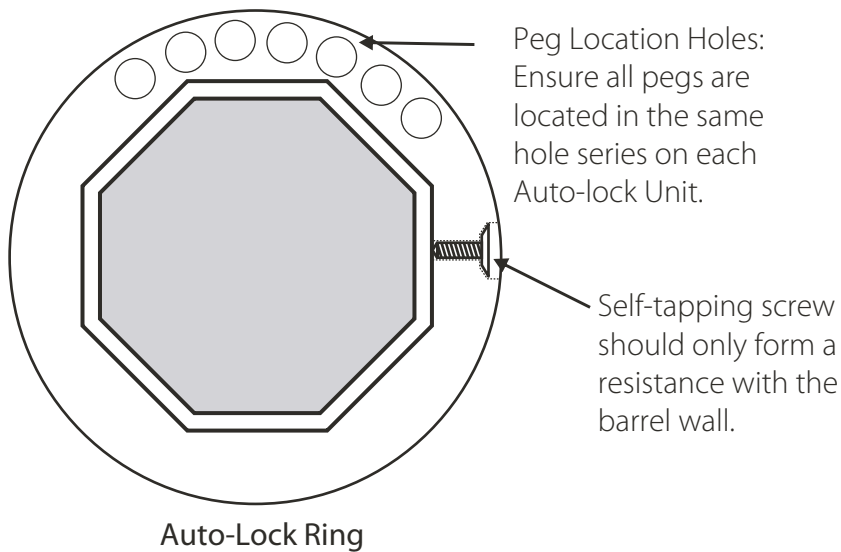

Auto-Lock Unit

Fig 4

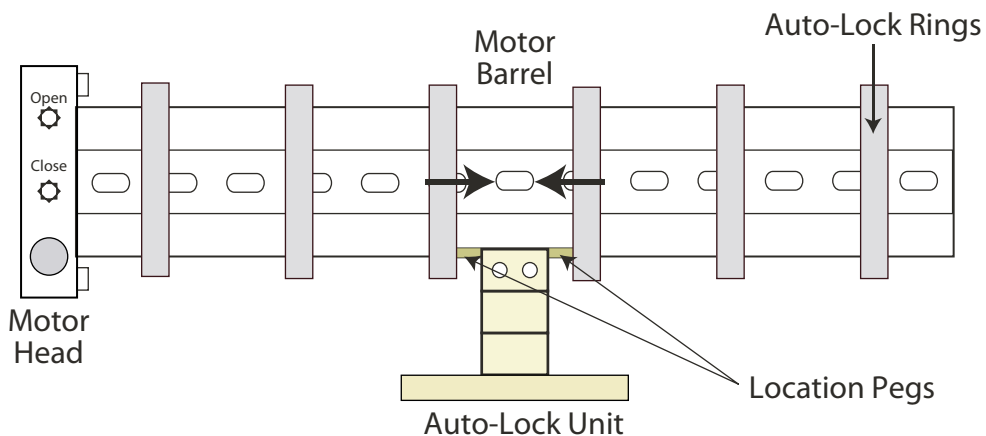

Auto-locking can cause marking to the internal face of the garage door over a sustained period of usage

Step 13 (cont'd) | Door Curtain Connection T Clips (Standard)

Connect the curtain to the motor barrel by placing the T Clip heads into the pre-pressed holes in the motor barrel. The T Clips should be positioned on either side of the pre-fitted spacer rings. Never use the barrel holes immediately either side of the spacer rings, as the T Clip units will foul each other.

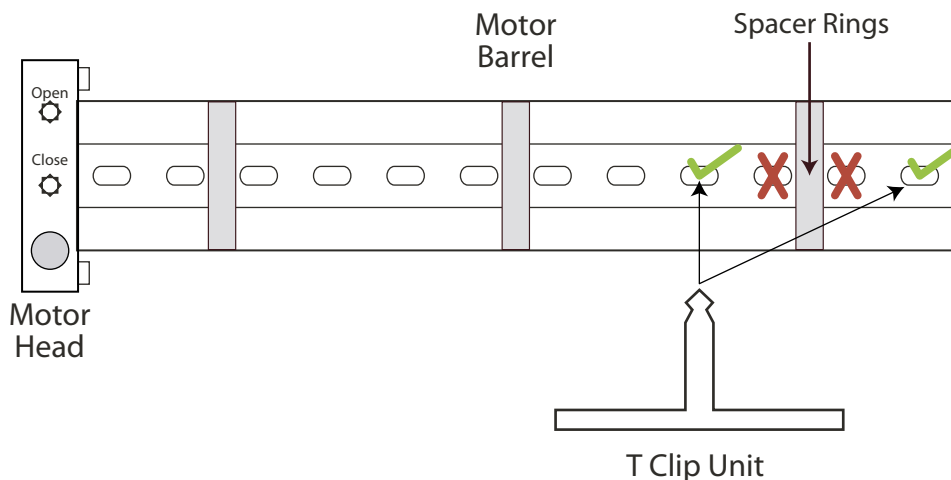

Step 14 | Setting The Motor Travel Limits

The motor limits are normally factory set to 2 barrel rotations in either direction, since we have already lowered the barrel to the close limit in Step 11, a maximum of four barrel rotations in the up position is possible.

Check the limit direction indicator sticker on the motor head (see diagram below) and minus the open limit approximately five screw driver rotations. Send the door open using a transmitter keyfob, and the door will stop half way on the open limit. Plus the open limit position and the door will move open in stages as you advance the limit adjuster. The fully open position should enable the bottom rail section to be fully in the guide section. Operate the door closed and open to ensure the correct setting has been retained.

To fine adjust both top and bottom limits

Once the above sequence has been carried out take the door to the half way point. Adjust the required limit. One rotation of the limit adjuster is equal to 10mm of door travel. Operate the door in the direction of the limit that has been finely adjusted to check on the adjustment. Repeat as necessary.

Left Hand Mounted

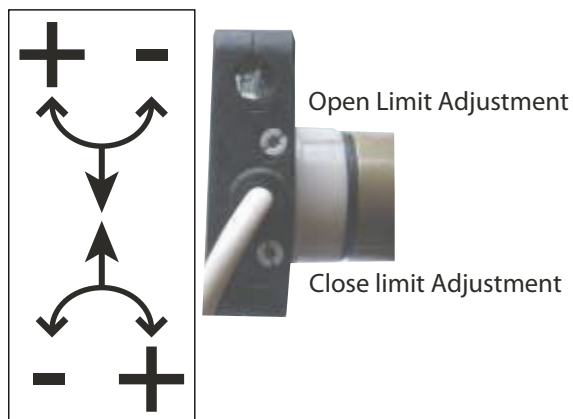

Right Hand Mounted

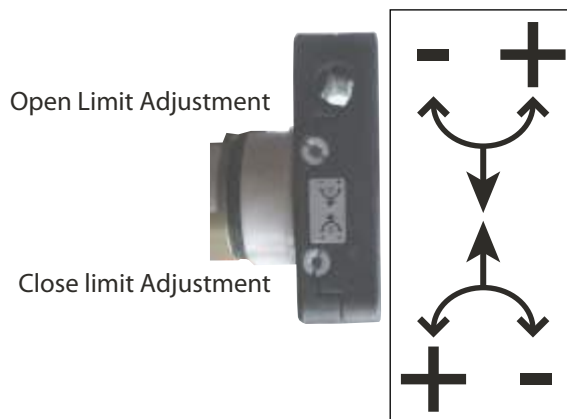

Note: The motor Unit has an inbuilt thermal trip Unit which will activate once the motor unit reaches a pre-determined temperature. Repetitive usage during the limit fine adjustment process can cause the motor to cut out. Please wait approximately ten minutes for the unit to return to a normal operating temperature.

Step 15 | Fitting Optional Internal Cover

The optional internal cover can only be installed once the limits are fully set

- (1) Clip the internal cover into the back box top retaining lip at approximately 10 degrees (See Fig 1).
- (2) Once clipped along the entire length of the back box top lip place the internal cover tight to the head plates.
- (3) Drill and fix in place with self tapping screws or pop rivets.
- (4) Drill a hole (See Fig. 2) in the front cover to allow the manual over-ride bar to pass through and locate into the motor unit. Secure the over-ride to the head plate with self tapping screws.

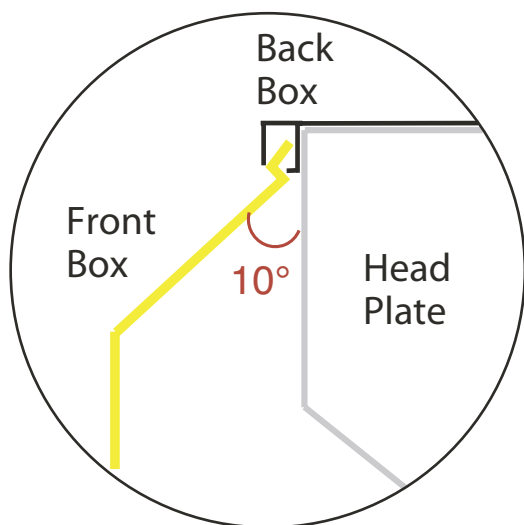
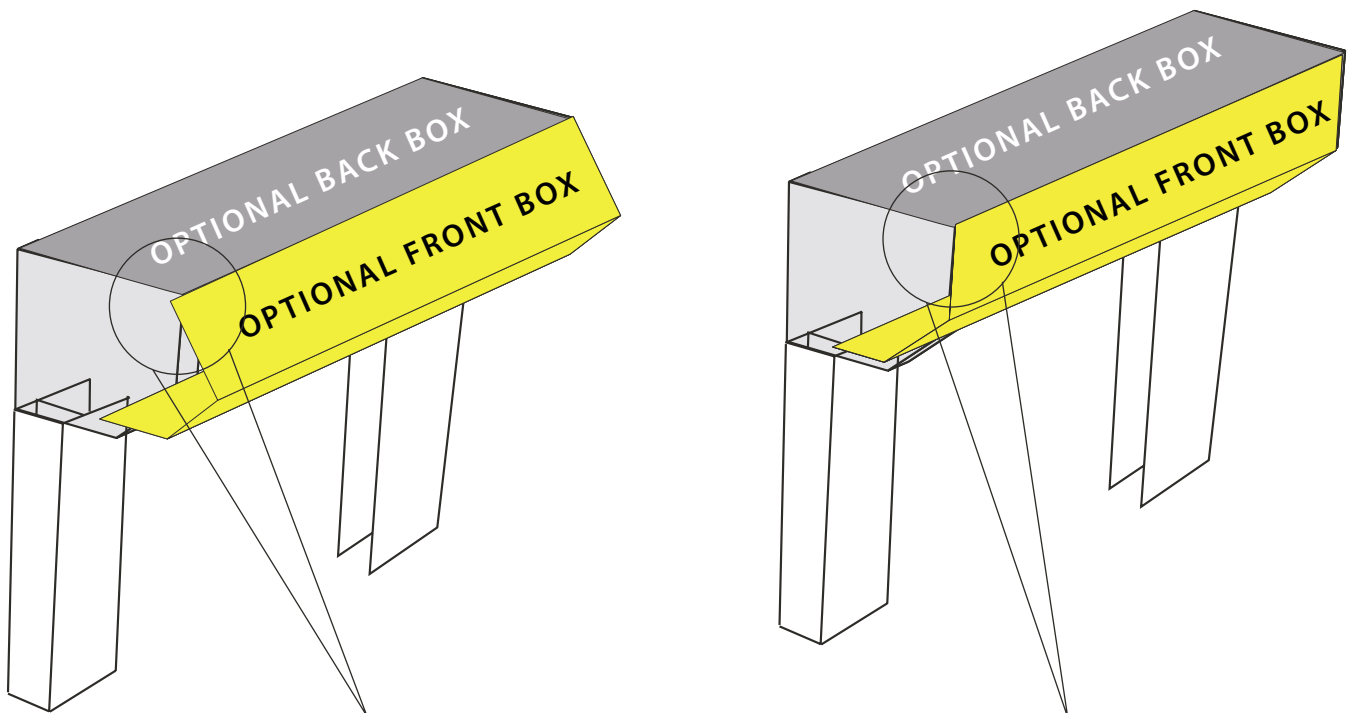

Fig 1

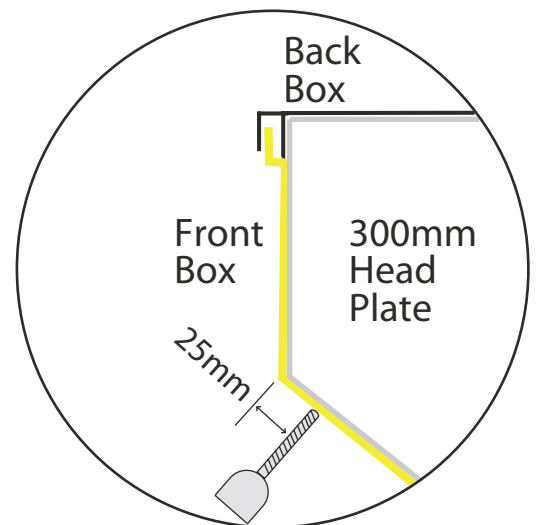

Fig 2

Note: Over-ride exit dimension for a 250mm head plate is 20mm

